



**ENKUR**  
MAKİNE MÜHENDİSLİK  
SAN. VE TİC. LTD. ŞTİ.

[www.enkurmakine.com.tr](http://www.enkurmakine.com.tr)





# CONTENT

---

About Us	Page: 03
Why Us	Page: 04
Hybrid Boilers	Page: 05 -06
Solid Fuel Burning System With Mobile Grate Stoker	Page: 07-08
Liquid & Gas & Coal fueled Hot Oil Boilers	Page: 09
Steam Boilers With Water Tubes	Page: 10
Steam Boilers	Page: 11
Hot Water Boilers	Page: 12
Steam Generators	Page: 13
Other Products	Page: 14 -15
Industrial Dryers	Page: 16
Pellet Press	Page: 17
Refrigeration Cabinets	Page: 18
Hammer Grinder Mills	Page: 19
Dust Cyclones	Page: 20
Conveying Equipment	Page: 21



**ENKUR**  
MAKİNE MÜHENDİSLİK  
SAN. VE TİC. LTD. ŞTİ.

## ABOUT US

Enkur Machine was established in Izmir in 2017. Since the day it was founded, Enkur has risen to the position of a company with a brand value in the steam and pressure boiler sector, thanks to the importance it attaches to quality and trust and the warm relationship it has established with its customers. Our company designs, manufactures and sells solid, liquid and gas fired Hot Water Boiler, Steam Boiler, Hot Oil Boiler, Chimney, Flue Gas Filter and other heaters and pressure devices, Pellet machine, dryer system and its product range, after-sales services improve itself day by day

### “ OUR VISION

Our vision is to provide the best solutions and products to our customers while keeping our passion of improvement at highest level. Therefore we aim to support our customers in their competition with our quality.

”

### “ OUR MISSION

We provide simple, applicable, ergonomical and economical solutions to our customers through our engineering.

We follow the technical improvements in the world and bring them to our customer to improve their productivity with their existing assets.

”

## WHY US?

---



### HIGH STANDARDS

We offer our customers high standards of service.



### INNOVATION

We are constantly improving ourselves with R&D studies.



### DESIGN

We act with the awareness that design is an important part of production.



### PRODUCTION

We are working to further expand a wide range of products.



### ENGINEERING

Our expert teammates are always ready to meet the needs of our customers.

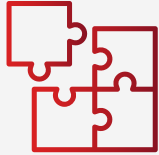

### INTEGRITY

Our customers, our teammates; we offer integrity with our production and service process.

## WE AIM BEYOND ORDINARY SERVICE QUALITY

---

As Enkur Mechanical Engineering, we adapt to the requirements of the technology age with our R&D activities, and constantly improve ourselves in our products, production speed and quality. Our company, which can transform fossil fuel energy into heat energy with environmentally friendly systems, has a different position from its competitors with its expert engineers.

# HYBRID BOILERS

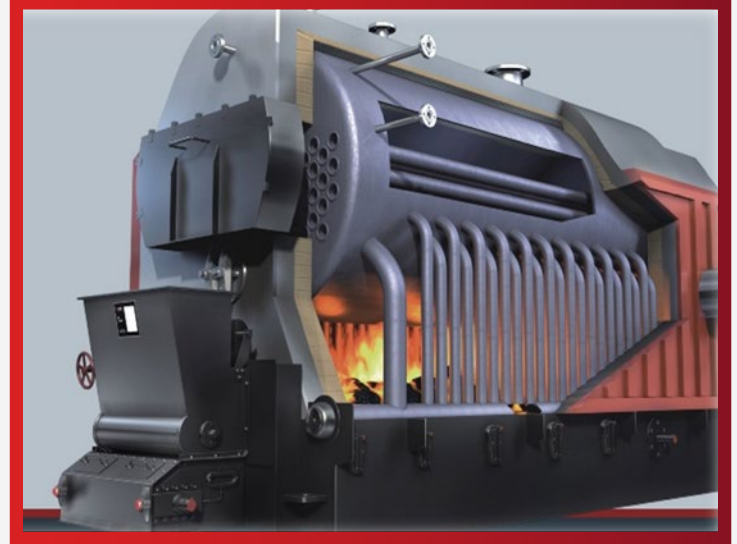

Solid fuel fired boiler consist of two parts, water-tube and fire- tube type boilers in a single united body. Primary furnace as water- tube (tube+bar) boiler mounted on a rotating grid is manufactured as high enough height to from a large volume of combustion chamber on the grill. Scotch type fire-fume tube type boiler and flame radiation type water tube boiler are connected to each other by means of water collector.

High-volume combusiton chamber is required for burning solid fuels, to keep flame length high and the maximum level of efficiency. Flame-flue type boiler is the two pass type and designed so that the smoke passages appropriate velocity.

Due to the sufficient smoke passage in the boiler very large portion of produced heat remains in the boiler, and used fort he production of steam. With a large steam volume the boiler can respond to system immediately to withdrawals of peak steam, water tube steam generation by means of primary combustion chamber provides fast steam for urgent steam need. Flame- smoke-tube boiler pipes can be changed easily by means of front and rear doors.

# HYBRID BOILERS

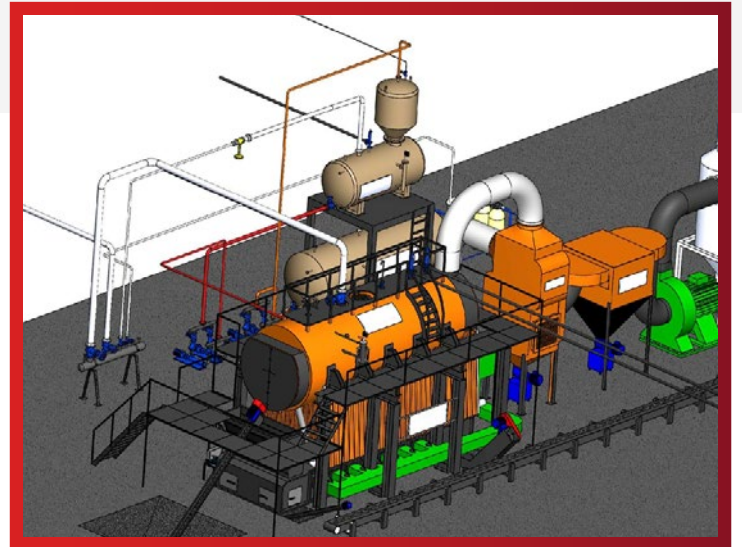

## SOLID FUEL BURNING SYSTEM WITH MOBILE GRATE STOKER



It is a conveyor type grate mounted below the primary combustion chamber which is surrounded by water tube membrane walls. Mobile grate is manufactured with special heat-resistant alloy cast iron material. Chain beans are designed so that; combustion air flows between them, which allows the entire surface of the grate for proper combustion. Burning capacity can be maintained at the desired level by means of plurality of air vents and flaps deemed necessary from the bottom of the grate. Using the inverter, the speed of the stoker is adjusted according to the efficiency of combustion of the coal loaded onto the grate.

Coal begins to burn at the inlet of combustion chamber just after laying on the grate, and continues to burn until the end of the grate in a homogeneous manner.

Mobile grate unit is shipped from our factory as completely assembled. As a separate unit the boiler is placed onto the conveyor grate with a mobil crane. This process allows for field installation is finished in a very short time. Boiler and conveyor grate placed on a flat concrete floor allows customers to minimize the cost of construction; this is one of the most important advantages.

Coal to be burned must be of suitable quality as defined regulations by the ministry of environment. Coals with low ashe, moisture and sulfur content and high calorie value should be preferred. The conveyor grate coal burning systems which is the mostly used in the World and is one of the improved design of solid fuel firing systems are used in our steam and thermal oil boilers. Conveyor grate is manufactured from special alloy heat-resistant cast iron material. Chain links; has been designed so as to allow combustion on the entire surface with thin formed air outlets between them.



# SOLID FUEL BURNING SYSTEM WITH MOBILE GRATE STOKER



It is a conveyor type grate mounted below the primary combustion chamber which is surrounded by water tube membrane walls. Mobile grate is manufactured with special heat-resistant alloy cast iron material. Chain beans are designed so that; combustion air flows between them, which allows the entire surface of the grate for proper combustion. Burning capacity can be maintained at the desired level by means of plurality of air vents and flaps deemed necessary from the bottom of the grate. Using the inverter, the speed of the stoker is adjusted according to the efficiency of combustion of the coal loaded onto the grate.

Coal begins to burn at the inlet of combustion chamber just after laying on the grate, and continues to burn until the end of the grate in a homogeneous manner.

Mobile grate unit is shipped from our factory as completely assembled. As a separate unit the boiler is placed onto the conveyor grate with a mobile crane. This process allows for field installation is finished in a very short time. Boiler and conveyor grate placed on a flat concrete floor allows customers to minimize the cost of construction; this is one of the most important advantages.

Coal to be burned must be of suitable quality as defined regulations by the ministry of environment. Coals with low ash, moisture and sulfur content and high calorie value should be preferred. The conveyor grate coal burning systems which is the mostly used in the World and is one of the improved design of solid fuel burning systems are used in our steam and thermal oil boilers. Conveyor grate is manufactured from special alloy heat-resistant cast iron material. Chain links; has been designed so as to allow combustion on the entire surface with thin formed air outlets between them

# LIQUID & GAS & COALFUELED HOT OIL BOILERS



The steam might be high temperatures at under high pressures, but capital cost, as well as operation and maintenance costs are very high.

•However the thermal oil boilers can be very easily to raise temperature up to 300°C, under atmospheric pressure.

•Thermal oil temperature is adjustable the operation range up to 300°C. However, steam temperature haven't to going up saturated steam pressure.

•Corrosion and limestone are not in thermal oil boilers.

•No freezing is without running under ambience conditions.

•Thermal oil boiler design and oil piping installation should be supplied continuous oil flow without any stationary sections.

•Thermal oil boilers are assembled single spiral and double or triple spiral one inside the other in a spiral tubes.

•The boilers are manufactured under EN Standards, according to 97/23/PED – Pressurized Vessel Directives.

•“CE” certificates are available according to 97/23/PED within B+F modules

# STEAM BOILERS WITH WATER TUBES



Water tube boilers are ideal for high pressure and great volume steam applications.

- Water tube boilers are possible to design pressure above 15 bars and steam capacity above 40.000 kg/h.

- The boilers are obtained high efficiency, if their designs are well.

- Particularly, their efficiency are well to compare to other types, for solid fuel combustion systems.

- Water tube boilers are ease designed and high efficiency for burn low-calorie coals and combustible wastes.

- The front furnace isn't necessary for solid fuel combustion system. They can be designed as mono-block type.

- Boiler water volume capacity are small and therefore they are very quickly reached full capacity.

- The manufacture is performed under EN Standards, according to 97/23/PED – Pressurized Vessel Directives.

# STEAM BOILER



- Steam Boilers are which have cylindrical, three passes and flame/smoke tube, burned with liquid and gas fuel.
- The boiler steam capacities are available from 400kg/h to 16.000kg/h.
- The boilers are manufactured up to operation pressures 15 bars and heating surfaces up to 400m<sup>2</sup>
- TS 377 EN 12953, TRD design standards are applied to design and materials are used according to TS EN 10028, TS EN 10216 and TS EN 10217 material standards.
- “CE” certificates are available according to 97/23/PED within B+F modules.
- The boiler readily respond to instantaneous steam demands, by means of great steam volumes.
- Low flue gas temperature and high boiler efficiency are obtained, by means of three passes and flame/smoke tube.
- Reduced NOx emission is obtained from the flue gas by means of low heated in the combustion chamber.
- Undesirable thermal stresses are eliminated by means of the full corrugated combustion chamber.

# HOT WATER BOILERS



## TYPES

Hot water boilers are divided into 3 groups as solid, liquid and gas fired hot water boilers.

## CAPACITY

Solid fuel-fired types have a heat capacity of 280-11000 kw, liquid and gas-fired types up to 930 kw.

## DURABILITY

In addition to their standard production of 3-5-7 bar; hot water boilers resistant to higher pressures can be specially produced.

## USAGE

The combustion chamber design has a volume that can burn all types of coal and can provide high radiation heat input. The burning system can be easily intervened, and the simple control panel facilitates the use.

## OTHER INFORMATION

Boiler bodies are covered with aluminum foil glass wool to minimize heat losses. In addition, the heat retention in the combustion chamber has been adapted to a low level in order to minimize the emission of harmful gases.

# STEAM GENERATORS



- Steam generator are which have radiation type, flame/ smoke tube, fired liquid and gas fuel.
- The generator steam capacities are available from 100kg/h to 2.000kg/h.
- TS 377 EN 12953, TRD design standards are applied to design and materials are used according to TS EN 10028, TS EN 10216 and TS EN 10217 material standards.
- “CE” certificates are available according to 97/23/PED within B+F modules.
- Need small installation area because of compact size.
- The boiler produces steam quickly.
- The boiler efficiency is high, because of radiation heat input is high.
- Installation is simple and readily, by means of package.
- Operation and maintenance are simple without any supervision.
- List of armatures:
  - Steam generator
  - Burner
  - Pressure control armatures
  - Level control gauges
  - Feeding pump and accessories
  - Condense tank and accessories
  - Water softener and filter
  - Control panel and cabling

# OTHER PRODUCTS



## DEGASSERS

- The degassers are used to get rid of O<sub>2</sub> and CO<sub>2</sub> gases contained in the steam boiler which feed water in their adverse effects on the metallic surfaces they contact.
- The gases are separated from the feed water by fracturing the water droplets into tiny particles via sprinkling while they are heated to 102°C and 60°C for O<sub>2</sub> and CO<sub>2</sub>, respectively.
- Degree of pitting induced by the feed water onto pump inlet is directly proportional to its temperature and therefore, the degassing tanks should be installed at high level. This might be accomplished by making use of vertically installed feed water tanks.
- Furthermore, this might also be solved by pressurizing the degassing tanks.
- The degasser heating requirement might partly be satisfied by flushing steam and partly by boiler steam. This may be considered as unwarranted consumption of steam, however, the degassers pay their costs when useful lives of the boiler and installation are taken into considerations.

## FUEL OIL TANKS

- The fuel tanks are used for storing fuel oil, diesel oil, gasoline and mineral oil.
- The fuel tanks are construction as single-skin or double skin, according to the demand.
- Double skin fuel tanks are in general provided for underground storage.
- The storage tanks for fuel oil are added with heating unit.
- The tanks are consisted of a cylindrical body and two dished heads. St37 type steel sheeting according to material specifications are used for their construction.
- Welds are made with submerged weld.
- The weld connections are made for nozzles used for filling, discharging, etc. as well as manholes to enter into the tanks.
- Sanding and painting are employed to the tanks, according to their purposes of use.
- Constructed according to the provisions of TS EN 12285-1, TS EN 12285-2 standards

# OTHER PRODUCTS



## STACK AND FILTERING SYSTEMS

✓ Economizer are used for heat recovery from the flue gases. Economizers can be feed hot water which plant requirement, without additional hot water boiler. Economizers can be used for primary and secondary combustion air heating, especially as a heat recovery unit called recuperator within the solid fuel system. Decreasing flue gas temperature by 20°C by heat recovery saves fuel as much as 1%.

## ECONOMISERS

- ✓ .Economiser are used for heat recovery from the flue gases.
- ✓ .Efficiency is depend on where the system is condensing and non-condensing.
- ✓ .These systems are paid to capital cost in few years. Their operations are free from additional supplementary power.
- ✓ .Economisers can be feed hot water which plant requirement, without additional hot water boiler.
- ✓ .Boiler efficiency can be increased when used for heating fed water to boiler
- ✓ .Particularly economisers are used within solid fuel system can be used for primary and secondary combustion air heating as heat recovery unit which name is recuperator
- ✓ .Decreasing flue gas temperature by 20°C by heat recovery saves fuel as much as 1%.
- ✓ .Ecomomisers are manufactured as smoke-tube, finned tube or stainless steel tube design, depending on the system requirements.



# INDUSTRIAL DRYERS



The founders of Enkur Makine are experienced in rotary dryer and stoker cooker. As Enkur Makine, we carry out the drying process of raw materials by drawing the heat we provide in solid fuel furnaces into the rotary dryer. As Enkur Makine, we are able to dry from 2 tons / hour capacity to 50 tons / hour capacity.

Ideal moisture content for pelleting should be 10-12%. If the raw material to be pelleted is not brought to this humidity rate, energy consumption will increase during pelleting and the combustion efficiency of the product will decrease. However, during transportation, the raw material will become lump and cause a jam between the pellet disc and the rolls. With the rotary dryers we produce as Enkur Makine, all desired products and raw materials, especially wood chips, pomace, chicken manure, sewage sludge, fruit pulp, cotton stalk, pulp, plastic wastes, can be dried.

Enkur Makine designed the rotary dryer as double-walled as a result of its experience and R&D studies, and by feeding the wet raw material and heat to the dryer from the same direction, it prevented the fire problem that may occur during drying. In addition, there is an emergency extinguishing device in an unexpected situation in our furnaces where we provide combustion with pellet or nut coal. With our researches and experiences, we have prevented the danger of gas compression and explosion in our furnaces because we draw the hot air in the furnace by sucking, not by blowing it into the dryer.

# PELLET PRESS

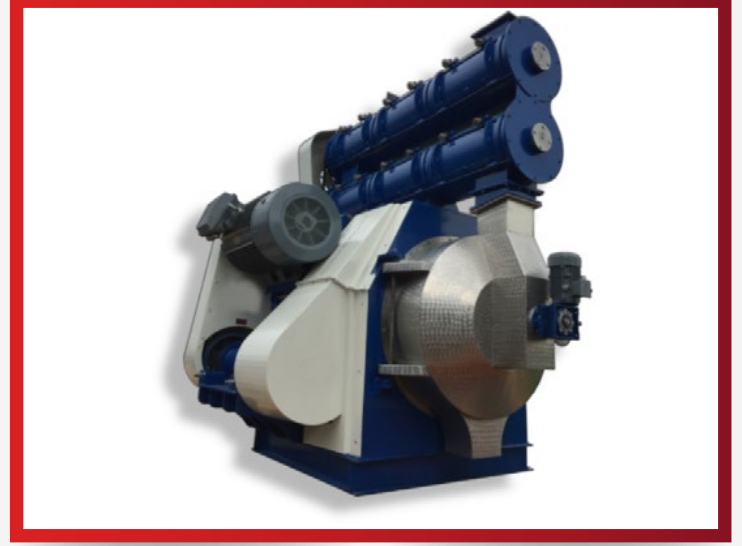

These are machines where the raw material of the pelleting process is transformed into a product. The product to be pelleted is fed to the pellet press after drying and grinding.

Before the pelleting process, the raw material is passed through the conditioner and the raw material is improved. Starch, molasses etc. required for the process. Here, the products are added to the raw material and blended well. The raw material compressed between the specially hardened rolls in the pellet machine and the specially manufactured disc comes out as pelleted.

Pellet press machines are known for the inner diameter of the disc inside the world. The companies that produce biomass pellets in our country generally import these machines from abroad. Enkur Makine founders have started to manufacture high tonnage and high quality pellet press machines as a result of long-term R&D studies on these machines which are newly produced in small capacities in our country. As a result of our work, we have reached a capacity of 7 tons / hour in a single machine for wood pellets and 22 tons / hour in a single machine for pomace and chicken manure pellets.

As Enkur Makine, we have the infrastructure and projects that can make the establishment of biomass facilities, which are very new in our country, more suitable than imported products and as domestic capital. This is a very important point in terms of providing service to you, our valuable investors, within 48 hours at the latest in case of emergency. Enkur Makine gives two years warranty to pellet press machines as well as all products it manufactures, and provides a lifetime service.



# REFRIGERATION CABINETS



The pellet product coming out of the pellet press is affected by the ambient humidity and is a machine that works with reverse air flow that prevents it from becoming sludge. If the pellet is allowed to cool by itself, sludge, transverse and longitudinal cracks occur and this degrades the quality of the pellet. It causes pollination in the pellet.

As a result of its experienced founders and R&D studies in this field, Enkur Makine has seen that the cooling cabinet is indispensable in the pelleting process. The cabinets we designed to cool the pellets with our work work with reverse air flow. What is the temperature of the environment where the production is made, the product leaves the pellet cooling cabinet at that temperature, preventing the pellet from absorbing the ambient moisture and sludge.

# HAMMER GRINDER MILLS

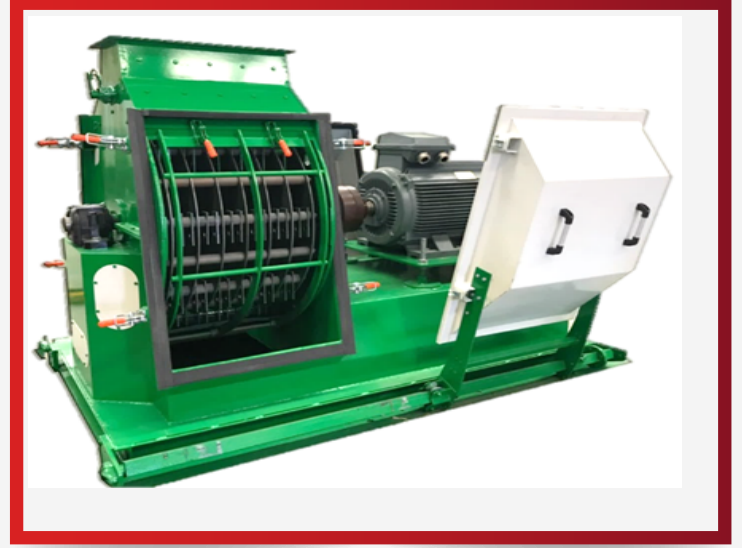
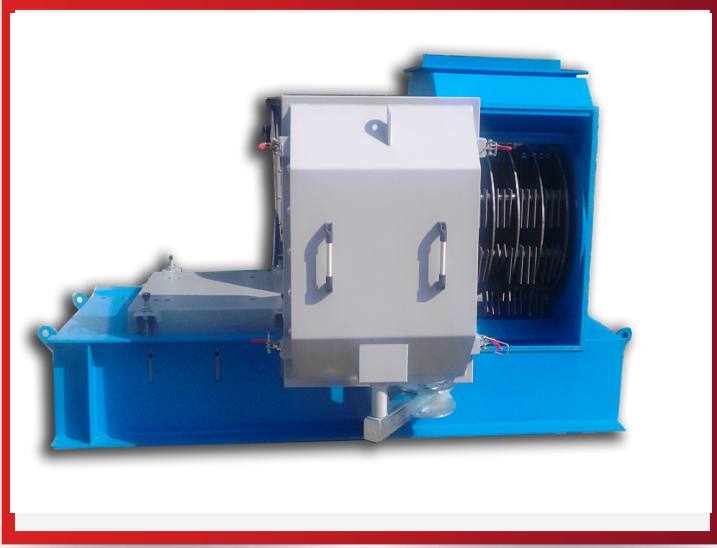

It is a wet and dry raw material grinding mill with its powerful rotor structure that can rotate in two directions. It provides easy and modular use thanks to its long-lasting hammer design and the sieve that can be changed according to the desired particle size.

Since drying of the raw material that is ground before drying will be easier, it increases the drying capacity. There is no need for a second grinding process by sieving in suitable sizes for pelleting.

It is possible to grind all kinds of products, especially wood chips, fruit pulp and feed, in our mills. Please contact our company for the power and designs that vary according to the product, the desired screen diameter and tonnage.

# DUST CYCLONES

---



Dust cyclones are dust filters that allow the air entering into it to fall to the cone under it by following the helical path. Through to the air locks on the lower cone of the cyclones, it allows the dust in the cyclone to be collected from the bottom of the cyclone without absorbing air from the outside.

Enkur Makine uses dust cyclones in industrial drying systems to keep the dust particles in the water vapor released into the air and to prevent them from being thrown from the chimney. In our pellet cooling cabinets, it does not throw dust into the environment by filtering the dust created by the pellet during transportation.

In addition, cyclones used in fan conveying systems prevent the compressed air made by the fan from damaging the next process by evacuating. In our country, many companies that try to use fan transport systems without investigating this issue suffer great damage.

As Enkur Makine, we continue to be your solution partner with our powder cyclone productions suitable for you, our valuable business partners.

# TRANSPORTATION EQUIPMENT

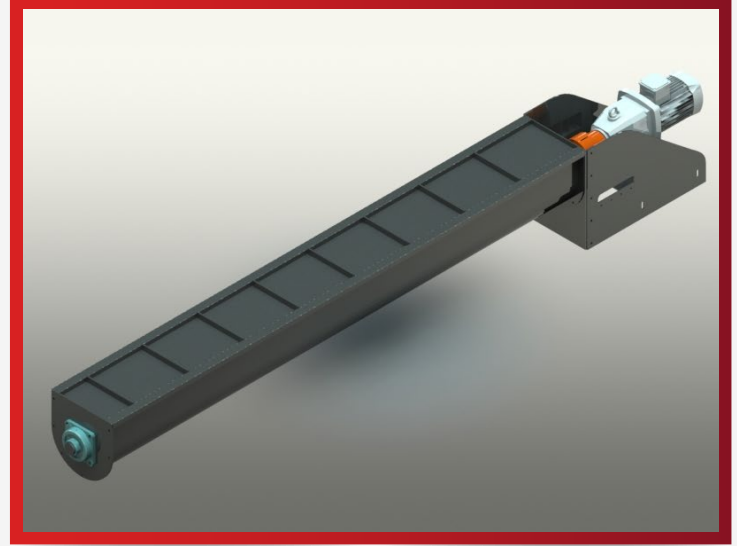
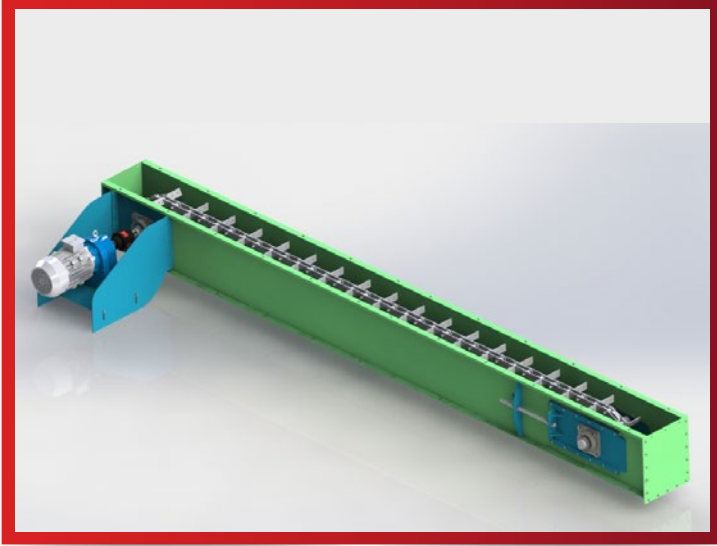

As Enkur Machine , we manufacture all our transport equipment in-house in order not to have problems in capacity in all facilities we have established and to prevent damage to the product after the product is obtained.

Spirals;

It is the transportation equipment we manufacture for the horizontal transportation of raw materials and fuel. We manufacture according to the U or pipe type suitable process. While the spiral production is made in our country, different from the random productions regardless of the product, the tonnage, according to the product type and capacity; By choosing pitch, motor, diameter and type, we make transportation equipment that will not have any problems for our valuable business partners.

Bucket Vertical Elevators;

It is the transportation equipment we manufacture to transport raw materials and products vertically and to lift them to a high point. We use plastic buckets in our bucket elevators. Thanks to our return lock motor reducer group, you will be prevented from being damaged in case of a possible energy cut and failure. Long-term use is provided thanks to the band tensioning system. Thanks to our observation covers in our bucket elevators, necessary controls can be made without hindering your work. As Enkur Makine, we will always try to do better to eliminate all the problems you experience in your bucket elevators.

Bucket Z Elevators;

Pulses, seeds, wheat, etc. It is the machine used during the transportation of agricultural products and highly fragile industrial raw materials from one point to another during the process or packaging. It is preferred because it does not damage the product during transportation.

It offers very efficient solutions in complex production lines due to its ability to carry simultaneously in horizontal and vertical axes. Horizontal and vertical axis lengths can be manufactured in desired dimensions. It is named as "horizontal z elevator" as it is designed to exit at an angle of 75° on the vertical axis. The reason it is designed to move with this angle is to extend the distance taken on the horizontal axis and to increase the product pulling capacity.

They are preferred in the transportation of industrial products with high specific gravity and / or high capacity solutions compared to standard type horizontal z elevators.

Chain Conveyors;

Chain conveyors are conveyor systems that are used to fill and unload silos horizontally or inclined without damaging the grain. Our conveyors are produced in different capacities and different model options. Our chain conveyors consisting of drive , boat and idler parts are completely assembled with a bolt-nut connection. Thus, assembly time of chain conveyors is shortened and technical service and maintenance is facilitated.



**ENKUR**  
MAKİNE MÜHENDİSLİK  
SAN. VE TİC. LTD. ŞTİ.

**THANK YOU**



**ENKUR**  
MAKİNE MÜHENDİSLİK  
SAN. VE TİC. LTD. ŞTİ.

**Contact US:**

Phone : +90 232 436 01 30

E-mail : [info@enkurmakine.com.tr](mailto:info@enkurmakine.com.tr)

Web : [www.enkurmakine.com.tr](http://www.enkurmakine.com.tr)

Address : Kazım Dirik mah. 367/7 sok. No:14  
A Blok D:521 Bornova/İzmir/Turkey

[www.enkurmakine.com.tr](http://www.enkurmakine.com.tr)